

### Specifications

The top of the STK line, with 6000kg permissible payload. The steel structure is covered with a walkable upper plating, protecting the tracks internal components from falling particles, or dripping fluids. Modularly extendable structure to fit to the customer's specifications.

### Available options:

- Double carriage,
- Automatic lubrication
- Ina, Bosch Rexroth, Schneeberger, Hiwin, Thk brand guidance system.
- Extended carriage for carrying welding power source and wire barrel
- Inner cable chain (there is no cable chain out of the track).



<u>Technical Data</u>		<u>Only Robot</u> (Including Tool & Workpiece)	<u>With Additional Static Load</u> (Including Robot & Additional Equipment)
<b>Max. Payload</b>	<i>(per carriage) kg</i>	4.000	6.000
<b>Max. Speed</b>	<i>m/min</i>	120	102
<b>Max Acceleration</b>	<i>m/s<sup>2</sup></i>	2	1,9
<b>Available stroke</b>	<i>travel length</i>	From 2 m, in 1 m steps	
<b>Total length</b>		Stroke + 2 m	Stroke + 2 m
<b>Robot Payload</b>	<i>kg</i>	240-700	
<b>Max. Robot Weight*</b>	<i>kg</i>	2.000	
*Includes tool, workpiece, options			
<b>Mounting position</b>		Floor, Wall**, Ceiling, Elevated***	Floor, Wall**, Ceiling, Elevated***
**In case of wall mounting, maximum payload reduces to half			
***Ask for detailed information about it			
<b>Repeatability</b>	<i>mm</i>	± 0,01	± 0,01
<b>Life</b>	<i>million meter</i>	10	10

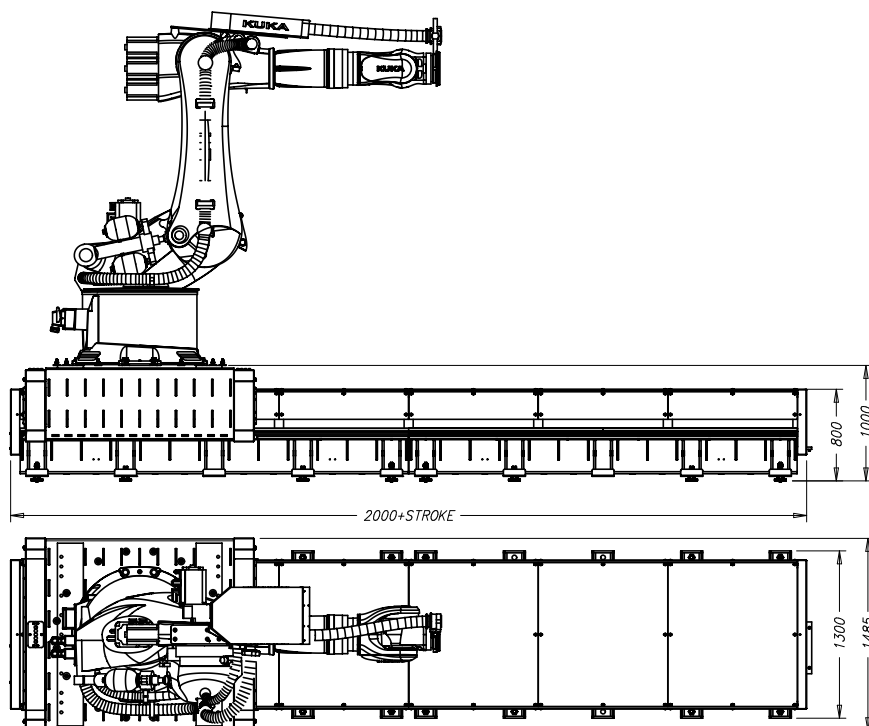

© 2023 ADMEX. All rights reserved.